

# SCIDL Data Exchange Project

The Department of Workforce Development (DWD) is a State of Indiana Agency with a stated Mission Statement of advancing and cultivating local economic growth by building a world-class Indiana based workforce thru partnerships and practice.



Primary services offered by DWD include WorkOne Center providing job posting, candidate recruitment, and job placement assistance, Unemployment Insurance, labor market information, regional workshops, and professional training. The DWD previously created a new job matching system solution as one of several active applications utilized to deliver DWD's core services. Internal data and user information previously existed in multiple places within the DWD network of disparate data models which have evolved into their current day solution architecture. DWD users and agency staff were limited to their access of global network information and were required to enter duplicate information while accessing the network.

The challenge faced by the DWD was their network was not integrated nor collaborative across all the various solutions. Each system used a different technology with unique capabilities to exchange data via a web-based service. This resulted in an inefficient, costly system with low user experience. The agency's goal was to use an Enterprise Service Bus (ESB) technology and create a solution that could manage data traffic between the various systems comprising the DWD network.

RCR Technology was selected to help the DWD to achieve its technology goals based on our strong capabilities around big data, integration, and application development skills.

## ■ *Project Requirements and Scope*

RCR Technology provided the project requirements based on DWD solution goals and developed the technical solution to solve the DWD problem(s) by creating the Single Common ID Layer or SCIDL Data Exchange. **This solution provided the following capabilities:**

**Data pre-population:** When a record containing common data is inserted or updated in one of the core service applications, the common data is automatically inserted or updated to other core service applications.

**Service record update:** The service records that are created or updated in one core service system also create an appropriate service in another core service system.

**Single user sign-on:** Data sharing will help to improve customer usability with respect to user identification and authentication for all the core service applications.

**The on-going data exchanges between the existing systems and the new job matching system is realized through real time enterprise-wide Service Oriented Architecture (SOA) interfaces between the systems.** The SOA is

implemented by using web-enabled services and technologies, primarily HTTP, XML and SOAP. The software to implement these technologies will be an Enterprise Service Bus (ESB).

## ■ *Project Solution*

A brief technical summary of the custom solution that RCR Technology created for the DWD, follows below; show cases not only our core capabilities around big data, but also demonstrates our flexibility to work with many commercially available or custom applications as required by any particular project.

All the core services participating in the data exchange expose a web service and creates a web services client. All web services use the ESB, so that it can accomplish both the data pre-population task as well as the service record update task.

One of the important factors in designing a multi-system interface is to have a consistent and accurate means of communicating information to the record/client identification. To accomplish this, the interface strategy included a numerology plan and a set of data fields used in cross system identification. Important to the ultimate solution design was a profile rank of various system keys (user ID/log-on) and a unique algorithm to manage required keys to needed records in all systems. These keys are critical to the source systems as it has historical records with inconsistent information in the normal matching data elements. The other system counts on the common people data matching fields used by most informational management systems managing client data. The RCR Technology solution maintains integrity of all keys (user ID/log-on) throughout. A data base was then created to manage all of client data called the Master Client Index (MCI).

The data base structure contains all the keys for the DWD source systems.

### **Following are the key fields for client matching between DWD various systems:**

- Common Identification (ID)
- Social Security Number (SSN)
- First Name
- Last Name
- Gender
- Date of Birth (DOB)
- Address Street
- City
- Zip Code

## ■ *Architecture*

The RCR SCIDL Data Exchange systems utilize SOAP wrapped XML files passed to and from it to communicate with other systems as its web services architecture. Source systems communicate via SOAP web services using the Request/Response method.

Furthermore, the ESB receives information in both ways; SOAP XML Packets and SOAP Messages to be effective while communicating with each vendor.

RCR designed SCIDL Data Exchange to program the ESB to accomplish to accept both web service types. Additionally, a key feature to the ESB called Polling was added to the architecture. This capability allows sources systems that communicate at different data absorption rates to operate independently from each other. The SCIDL Data Exchange acts as the traffic flow monitor, storing and transmitting data at the optimal speed for the source system to operate efficiently and effectively. The ESB database stores all transactions clearing them out of the queue periodically.

**The SCIDL Data Exchange architecture can operate equally effectively on any ESB technology.**

*Diagrams below.*

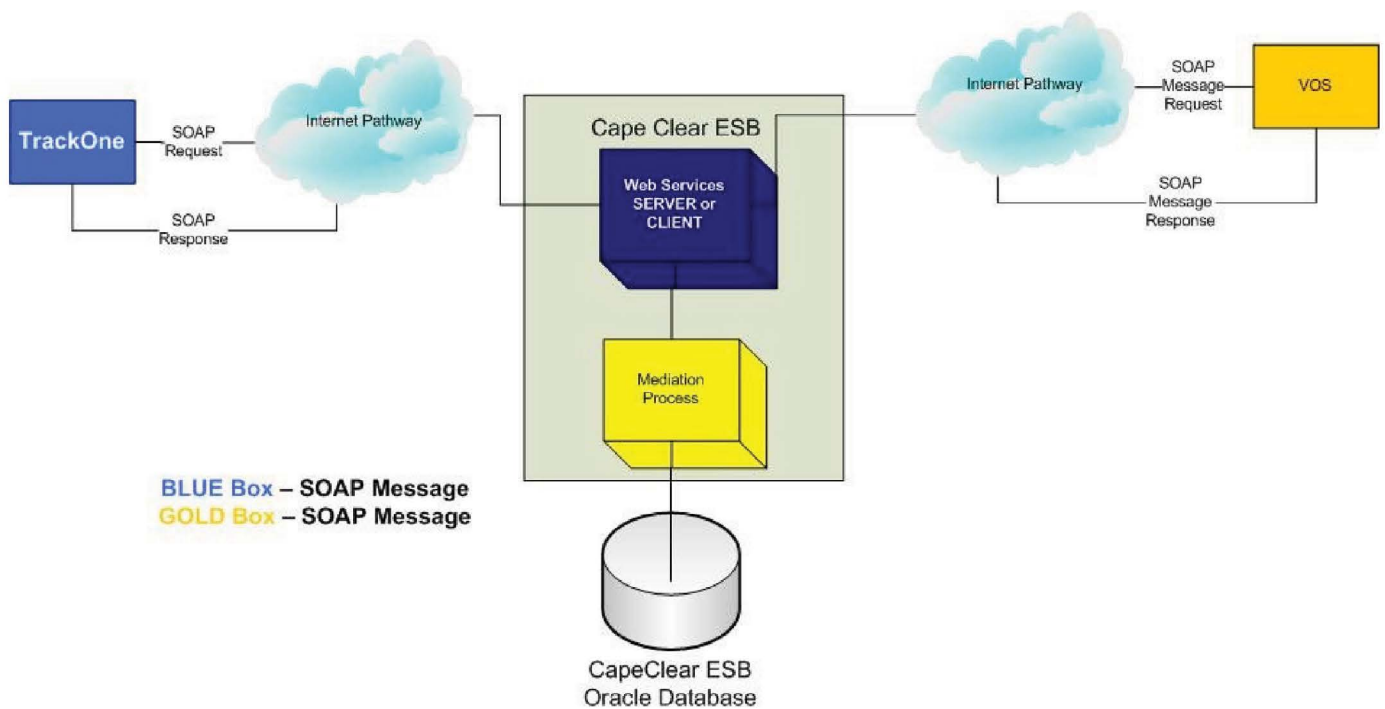
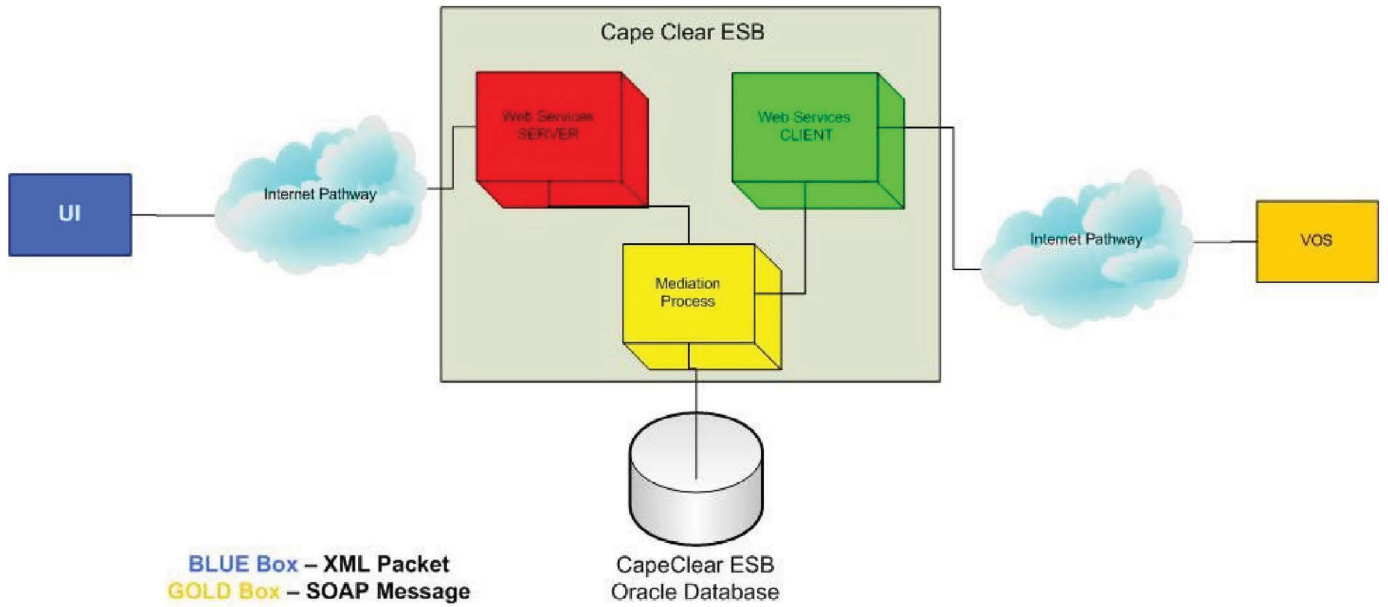

## SCIDL Matching Cleansing Process – High Level

Figure 1 - ESB COMMONDID Transformation Process

